

MechNEWS

January 2003

Welcome

Welcome to the first, monthly edition of MechNEWS™, a service provided by MechSigma Consulting, Inc. The purpose of MechNEWS™ is to highlight issues related to mechanical dimensioning and tolerancing. Each newsletter will contain a discussion about a tolerancing issue that is sometimes misinterpreted, misunderstood or perhaps not widely known. We welcome suggestions from our readers for additional topics, and we'll also include topics related to problems that we've encountered. We hope you'll find this useful, and please feel free to [tell your colleagues about it](#).

Since this is our first newsletter, it seems appropriate to tell you a little about us. MechSigma Consulting, Inc. has developed an **innovative methodology**, which we call MechPRO™, that links mechanical assembly tolerancing requirements to part variation controls, to improve your mechanical tolerancing process. The MechPRO™ methodology saves you time and money by *improving assembly fit*, *improving manufacturability*, and *reducing design changes*. MechPRO™ is supported by our software tools, MechTOL™ and MechDATA™. In addition, we offer a variety of geometric dimensioning and tolerancing classes, along with mechanical tolerance stacks training. We support both Six Sigma (statistical) and traditional approaches to tolerancing.

Since our philosophy is to focus on mechanical dimensioning and tolerancing, let's go to our first topic, which focuses on ASME Y14.5M-1994's Rule #1. We hope you enjoy this, and all subsequent issues of MechNEWS™.

Rule #1 "Rules"

In our many years of applying and teaching geometric dimensioning and tolerancing (GD&T), rarely have we found anyone who understands "Rule #1." Fewer people understand the impact that Rule #1 has on the design and manufacture of their parts. This article hopes to explain some of the issues relative to this rule.

Free Newsletter

If you are not on our emailing list and want to receive

MechNEWS™, contact us at:

NEWS@mechsigma.com

What is Rule #1?

Initially, Rule #1 seems complicated. Understanding the reasoning behind the rule makes it easier to comprehend. Let's take a look at the definition from the Dimensioning and Tolerancing standard, ASME Y14.5M-1994¹.

"2.7.1. Individual Feature of Size (Rule #1). Where only a tolerance of size is specified, the limits of size of an individual feature prescribe the extent to which variations in its geometric form, as well as size, are allowed."

The Y14.5 standard further describes the variation allowed by size tolerances.

"2.7.1.2(a) The surface or surfaces of a feature shall not extend beyond a boundary (envelope) of perfect form at MMC (maximum material condition)... No variation in form is permitted if the feature is produced at its MMC limit of size..."

Rule #1 requires that a size feature must always *fit* within a *perfect form envelope*. The size of this envelope is the feature's MMC size. Thus, Rule #1 is commonly referred to as the "Envelope Principle" and is often remembered by the catchphrase "Perfect Form at MMC." The figure to the right demonstrates the reasoning behind the Envelope Principle.

In this figure, the pin must always fit *inside* a perfect cylinder whose size is $\varnothing.501$ (the MMC of the pin). Likewise, the hole must always fit

(Continued)

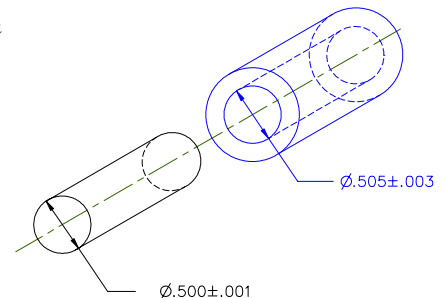

Events:

The next GD&T committee meeting is Feb. 3-6, 2003 in Las Vegas, NV. These meetings are open to the public.

For more information, contact ASME or their website at: <http://asme.fmpdatabase.net/calendar/action.lasso?-database=calendar.fp3&-layout=web&-response=Detail.lasso&-recordID=36917&-search>

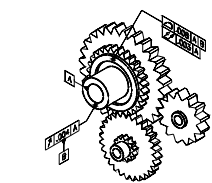

MechSigma Consulting, Inc.
7301 Moss Ridge Rd.
Parker, TX 75002
Tel: 972.808.0153
Fax: 972.442.2398
info@mechsigma.com
www.mechsigma.com

1. ASME Y14.5M-1994 is the current release of the Dimensioning and Tolerancing standard, published by the American Society of Mechanical Engineers. To obtain a copy, go to <http://www.asmeny.org/cgi-bin/WEB017C:888870+0001+00+00000+N00594>.

outside a perfect cylinder whose size is $\phi .502$ (the MMC of the hole). In this example, the pin must be perfectly cylindrical and straight if it's made at $\phi .501$. It is allowed to bow as much as the envelope will allow as it departs from MMC. Therefore, the axis of the LMC ($\phi .499$) pin may bow as much as $\phi .002$. Likewise, if the hole is made at $\phi .502$, it must be perfectly cylindrical and straight. Its LMC axis, on the other hand, may bow as much as $\phi .006$.

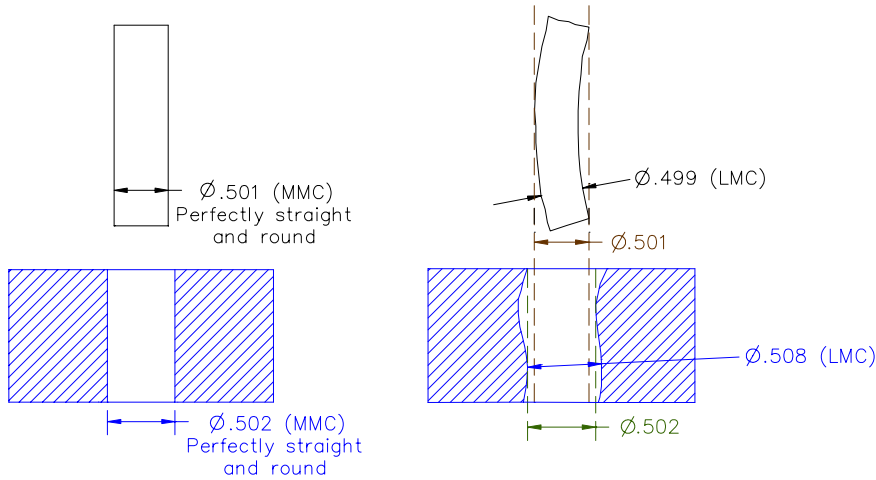

What if the features aren't supposed to fit together?

Although there are exceptions to Rule #1, *Perfect Form at MMC* is the default. This is needed for parts that are supposed to fit together, but what about those that aren't? Unfortunately, it is the default for those as well. The figure on the right shows an example where size features do not fit with other parts and do not require perfect form at MMC. Y14.5 allows us to take exception adding a note as shown. If an exception is not taken, the entire part must be contained within the MMC envelope.

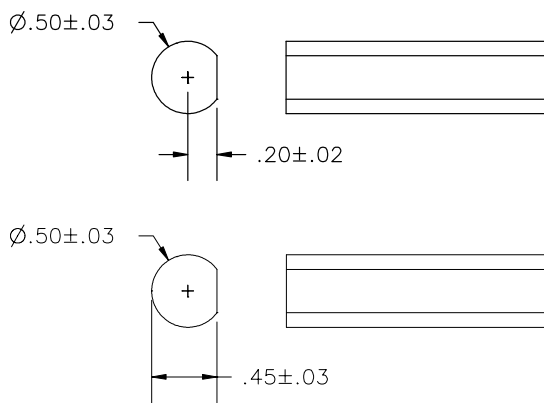
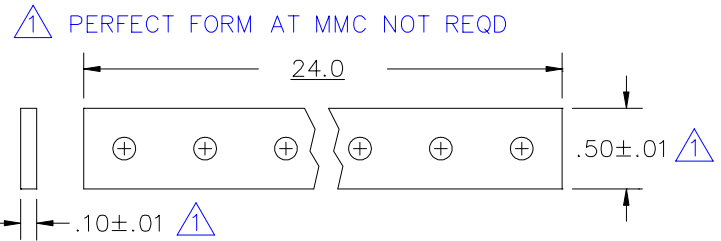

What about features that are partial size features?

Since Rule #1 applies only to size features, it's important to understand what a size feature is. Y14.5 defines a feature of size as "One cylindrical or spherical surface, or a set of two opposed elements or opposed parallel surfaces, associated with a size dimension." It's easy to identify holes, pins, slots, spheres, and similar "full" features as features of size.

For the top D-shaped extrusion on the left, one might argue that the $\phi .50$ dimension controls *some* opposed elements, while the $.20$ does not control opposed elements. For the bottom D-shaped extrusion, one might argue that both dimensions have opposed elements, *but that not all opposed elements are associated with one dimension*. Since Y14.5 doesn't explicitly define these as features of size, they are open to different interpretations.

The drawing below offers similar concerns. Per the definition, one might argue that the $.97$ dimension is a feature of size only in the middle portion of the part. This would allow the part on the right to be acceptable, which is an unlikely design requirement.

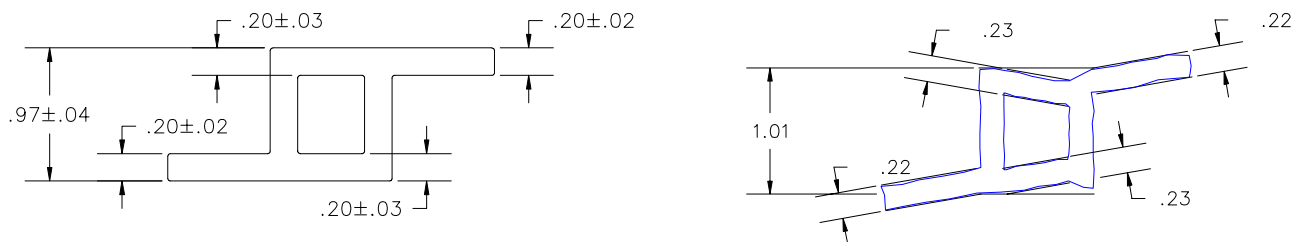

(Continued)

Mechanical Tolerancing Methodology

We offer a comprehensive methodology, *MechPRO™*, that takes your assembly tolerance requirements and automatically defines the (GD&T) controls and allowable tolerances to control part variation to Six Sigma quality. We offer: an analysis software tool, *MechTOL™*; a database software tool, *MechDATA™*, and a three-day workshop to support this methodology.

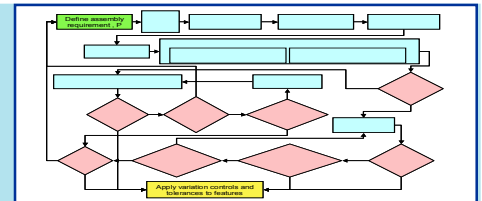

Engineering Services

MechSigma offers consulting in:

- Optimizing assembly and manufacturing tolerances for cost and quality.
- Performing tolerance analyses that trade off assembly tolerance requirements and manufacturability.
- Optimizing part documentation.
- Reviewing drawings to reduce manufacturing and inspection costs.
- Reviewing drawings for correct application of GD&T.
- Interpreting customers' and suppliers' drawings.

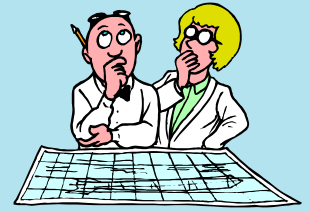

Comparing Y14.5 with ISO standards.

Although there are few differences between ISO (International Organization for Standardization) standards and US standards, Rule #1 is one of them. ISO defaults to "Perfect form at MMC *not* required" (sometimes called the Independency Principle). ISO adds a symbol to invoke an "envelope of perfect form at MMC."

Summary.

To conclude, we offer the following:

- For features of size that conform to the definition in Y14.5, the rules are simple. With a few exceptions, perfect form at MMC is the default. If one wants to take exception to it, it must be noted on the drawing.
- For features that *don't* conform to the definition in Y14.5, there are other tools that one should consider. A profile, for example, may work well for the parts shown. On other occasions, a note will clarify the "gray" areas. There is no perfect answer for each situation.
- Regardless of whether you use geometric controls or not, if your drawing (or another document referenced on your drawing) references Y14.5, Rule #1 is in effect. If the part manufacturer understands Rule #1 and the designer does not, the design may cost more than it should. If the designer understands Rule #1 and the manufacturer does not, the manufacturer may build parts that will not work properly. Understanding (by all) is the key to least expensive designs that will work properly. A



Public and On-Site Seminars

MechSigma offers several GD&T and Mechanical Tolerancing for Six Sigma courses. If you are interested, please take a look at our website: www.mechsigma.com/training.asp or the following:

- Description of GD&T courses: <http://www.mechsigma.com/MechSigma GD&T.pdf>
- Description of Mechanical Tolerancing for Six Sigma course: <http://www.mechsigma.com/MechSigma Mech Tol for Six Sigma.pdf>

If you are interested in signing up for a public offering, please call or [email](mailto:) us.

Geometric Dimensioning and Tolerancing

- Dallas, TX: March 24-26, 2003
- Atlanta, GA: June 9-11
- SanAntonio, TX: Sept. 8-10
- LosAngeles, CA: Nov. 10-12

Mechanical Tolerancing for Six Sigma

- Dallas, TX: March 27-28, 2003
- Atlanta, GA: June 12-13
- SanAntonio, TX: Sept. 11-12
- LosAngeles, CA: Nov. 13-14

Joke of the Month

Andy wanted a job as a signalman on the railways. The inspector asked him this question: "What would you do if you saw 2 trains heading for each other on the SAME track?" Andy said, "I would switch the points for one of the trains." "What if the lever broke?" asked the inspector. "Then I'd dash down to the signal box," said Andy. "And use the manual lever there." "What if lightning struck it?" asked the inspector. "Then," Andy continued, "I'd run back into signal box and phone the next signal box." "What if the phone was engaged?" "Well, in that case," persevered Andy, "I'd rush down out of the box and use the PUBLIC emergency phone at the level of the crossing up there." "What would you do if THAT was vandalized?" "Oh, well then I'd run into the village and get my Uncle Brown." This puzzled the inspector, so he asked, "Why would you do that?" "*Because he's never seen a train wreck!*"



We need your input!

- If you have a particular topic that you would like us to discuss in a future issue, please let us know.
- If you want to submit an article for a future issue, please send it.
- If you have a joke (acceptable for printing) that you are particularly fond of, please send it.

Please submit all correspondence to:

NEWS@mechsigma.com

Other Links

- Deploying Mechanical Tolerancing for Six Sigma <http://www.sme.org/cgi-bin/get-newsletter.pl?SIGMA&20020523&1&>
- MechSigma Executive White Paper: <http://www.mechsigma.com/Exec White Paper.pdf>
- Sign up to automatically receive MechNEWS™: NEWS@mechsigma.com