

## Welcome

Welcome to the March/April issue of MechNEWS™, a service provided by MechSigma Consulting, Inc. In this issue, we discuss how to use a pattern of holes as a single datum feature. Although it is easy to functionally justify a pattern of holes as a single datum feature, we don't find a lot of people who understand how to do this.

We hope you enjoy this issue of MechNEWS™ and continue to [tell your colleagues about it](#).

## Referencing a Pattern of Holes as a Single Datum Feature

Sometimes we want to use a pattern of features as a single datum feature. For example, if two parts are fastened together with clearance holes and bolts we should use the pattern of holes as a single datum.

Paragraph 4.5.8 of Y14.5 states the following.

Multiple features of size, such as a pattern of holes at MMC, may be used as a group to establish a datum when part function dictates. ... In this case, individual datum axes are established at the true position of each hole. These are the axes of true cylinders that simulate the virtual condition of the holes. When the part is mounted on the primary datum surface, the pattern of holes establishes the second and third datum planes of the datum reference frame. Where the secondary datum feature is referenced at MMC in the feature control frame, the axis of the feature pattern established by all the holes may depart from the axis of the datum reference frame as the datum feature departs from MMC.

Figure 1 shows a part with pattern of four  $\varnothing.144 +.005/-.002$  clearance holes that are basically located on a rectangular grid .530 apart. The part is fastened to its mating part with four .112-40 screws that fit through these clearance holes. Using the "fixed fastener formula" (see the [May 2003 newsletter](#)) we locate the holes to each other with a positional feature control frame,  $\varnothing.014 \text{ (M)} \text{ A}$ . By attaching a datum feature symbol on this feature control frame, we indicate that the four-hole pattern is datum B.

The drawing also uses a positional feature control frame to locate two  $\varnothing.520$  holes relative to  $\text{A B (M)}$ . By referencing datum B at MMC, we establish a framework of four true geometric counterparts (TGCs) that are fixed relative to one another. The diameter of the TGCs is the virtual condition size,  $\varnothing.128 (\varnothing.144 - \varnothing.002 - \varnothing.014)$ , and the distance between the TGCs is .530. (Continued)

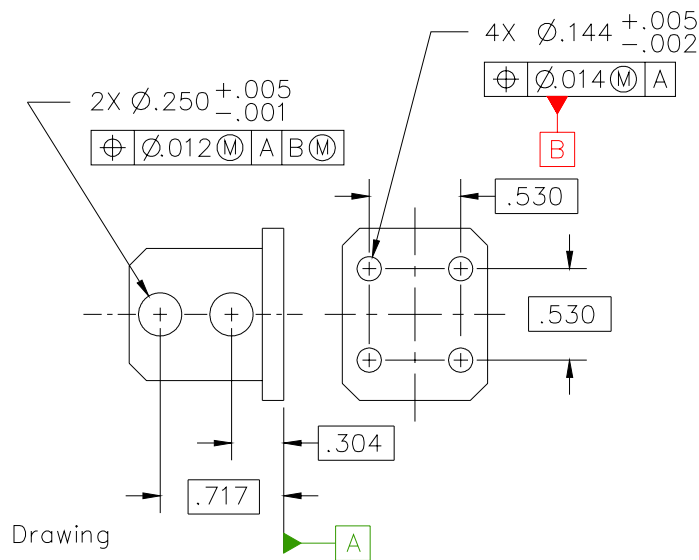
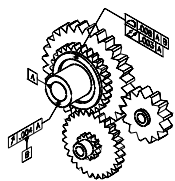

Figure 1

### Free Newsletter

If you are not on our emailing list and want to receive MechNEWS™, contact us at: [NEWS@mechsigma.com](mailto:NEWS@mechsigma.com)



MechSigma Consulting, Inc.  
7301 Moss Ridge Rd.  
Parker, TX 75002  
Tel: 972.808.0153  
Fax: 972.669.4028  
[info@mechsigma.com](mailto:info@mechsigma.com)  
[www.mechsigma.com](http://www.mechsigma.com)

## On-Site Seminars

Don't forget, MechSigma offers several GD&T and Mechanical Tolerancing for Six Sigma classes. We can customize these for your products. For more information, visit us at:

[www.mechsigma.com/training.asp](http://www.mechsigma.com/training.asp)



Figure 2 shows how we derive two perpendicular planes from the TGCs. These are centered between the TGCs and are perpendicular to the primary plane. These three planes restrict all six degrees of freedom. (See [Nov./Dec. 2005 newsletter](#)). For discussion purposes, we'll call the intersection of these planes "datum axis B."

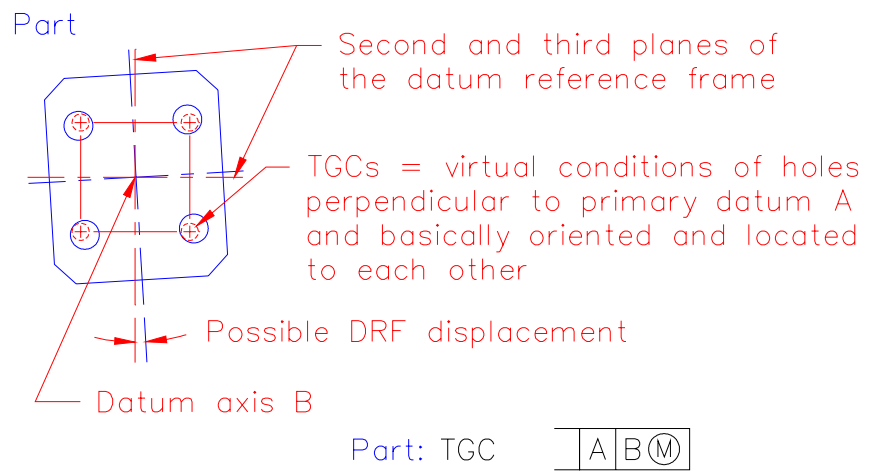

Figure 2

### Datum Reference Frame Displacement

Since each individual feature in the pattern clears its respective TGC the part is allowed to move (or displace) with respect to the three datum planes. We call this datum reference frame displacement. (See [Mar./Apr. 2005 newsletter](#).) The DRF is allowed to rotate and/or translate in any direction about datum axis B. Figure 2 shows a DRF displacement that only includes a rotation about datum axis B.

Although it appears that this might be difficult to inspect, the two-hole pattern could be easily inspected with a functional gage. The datum feature B simulator would be four  $\varnothing.128$  pins (perpendicular to a planar surface) that are located on a rectangular grid .530 apart.

### Datum Feature Pattern Referenced at LMC or RFS

A pattern of features can also be referenced at LMC or RFS. For the LMC case, the datum feature simulator is still a set of fixed-size TGCs. As with MMC, these virtual condition cylinders are basically located to each other. Since the TGCs are "inside the material", this would require softgaging, as opposed to using a hard gage.

Y14.5 does not clearly define what the datum simulator would be for the RFS case. Obviously, it would include a set of expanding or contracting simulators. Y14.5 does not detail how the simulators expand or contract. Should they adjust at the same rate? Should they all be the same size? Depending on the function of the design, the designer would know what he/she wants? He/she would need to provide detailed instructions for datum simulation on the drawing (or in the model).

### Summary

Functionally, there are some very good applications where we want to define a pattern of features as a datum. Our experience shows us that (typically for inspection reasons) few people do this. We often see drawings where the designer picks one feature (hole) as the secondary datum and another feature (hole) as the tertiary datum. This method will not necessarily accept all of the parts that will fit in the assembly because all of the holes are allowed to move around. The assembly doesn't care about any holes being "centered" on the mating part. In the assembly, all of the holes are all allowed to "displace" which is what happens when we use a pattern of features as a single datum.



## Joke of the Bi-Month



### Friendship Between Women:

A woman didn't come home one night. The next day she told her husband that she had slept over at a girlfriend's house. The man called his wife's ten best friends. None of them knew anything about it.

### Friendship Between Men:

A man didn't come home one night. The next day he told his wife that he had slept over at a buddy's house. The woman called her husband's ten best friends. Eight of them confirmed that he had slept over, and two claimed that he was still there.

## Course Descriptions

Description of GD&T courses:

<http://www.mechsigma.com/MechSigmaGD&T.pdf>

Description of Mechanical Tolerancing for Six Sigma course:

<http://www.mechsigma.com/MechSigmaMechTolforSixSigma.pdf>